



Resolute

ASX Announcement

18 November 2019

Syama Sulphide Circuit Update

Roaster repairs on schedule and expected to be fully operational by early to mid-December

Syama Underground Mine ramp-up progress

Gold production on budget with Resolute pouring 42,365oz in October

Production Guidance for FY19 maintained at 400,000oz at AISC of US\$1,020/oz

Resolute Mining Limited (Resolute or the Company) (ASX/LSE: RSG) is pleased to advise the repair program for the sulphide roaster at the Company's Syama Gold Mine in Mali (Syama) is progressing to schedule and within budget. The roaster is a key component of the Syama sulphide processing circuit and was taken offline in early October due to the detection of a crack in the main external shell (see ASX Announcements dated 10 October 2019 and 25 October 2019). The Company expects the roaster will be fully operational in early to mid-December.

The Syama roaster repairs are being managed using an Integrated Project Schedule which includes design, engineering, manning, procurement, planning, and execution. The repair methodology was developed in collaboration with Outotec, the original designer of the Syama roaster. Planning, procurement, contracting, and engineering design work is largely complete. The repair work is well underway with good progress being made in the installation of the secondary steel shell to the defective area where the crack occurred.

As advised in the Company's September Quarterly Activities Report, a detailed inspection of the main roaster chamber and structural assessment of the structural shell and related infrastructure has been completed by Resolute's technical team (see ASX Announcement dated 31 October 2019). Resolute is confident in the long-term structural integrity and operational capacity of the roaster, the associated infrastructure and production handling systems. Scheduled maintenance work has been advanced and included in the repair schedule where possible.

Resolute has confirmed the initial estimate of the total cost of the roaster repairs at US\$5 million. The Company is confident of completing the required repairs within this budget.

Automated underground mining activity at Syama has continued to ramp-up successfully. With the Syama roaster offline, the mining team have been able to prioritise drill stocks, drawpoint development, and focus on automation optimisation while also achieving further acceleration in mine production. The roaster downtime is expected to provide the opportunity to accumulate more than 300,000 tonnes of available underground ore on the run-of-mine pad. This significant stockpile of ore provides confidence that the Syama Underground Mine will be able to achieve nameplate capacity of 2.4 million tonnes per annum on a consistent and ongoing basis from January 2020 onwards.

In addition to the focus on the roaster repair schedule and the underground ramp-up, the Syama operating team have been successful in offsetting lost production from the sulphide circuit by processing stockpiled transitional oxide material through the Syama sulphide circuit carbon in leach infrastructure. This additional production, along with strong contributions from the Tabakoroni Open Pit Mine, the Mako Gold Mine, and the Ravenswood Gold Mine has allowed the Company to maintain Group production guidance for FY19.

In October, Resolute poured 42,365 ounces of gold despite the Syama roaster being out of operation for most of the month. The Company is pleased to affirm FY19 production guidance of 400,000 ounces of gold at an All-In Sustaining Cost of US\$1,020 per ounce.

Managing Director and CEO, Mr John Welborn, confirmed the successful repair of the Syama roaster, and the ramp-up of the Syama Underground Mine, remained primary objectives: "The roaster downtime is affecting what would otherwise be a highly productive period for Resolute as we ramp-up the Syama Underground Mine. Despite this setback we have poured more than 42,000 ounces of gold in October, an annualised production run rate of more than 500,000 ounces. We are working hard to repair the Syama roaster and are committed to delivering on our ambitions at Syama by delivering stable long-life low-cost production from the Syama Underground Mine."

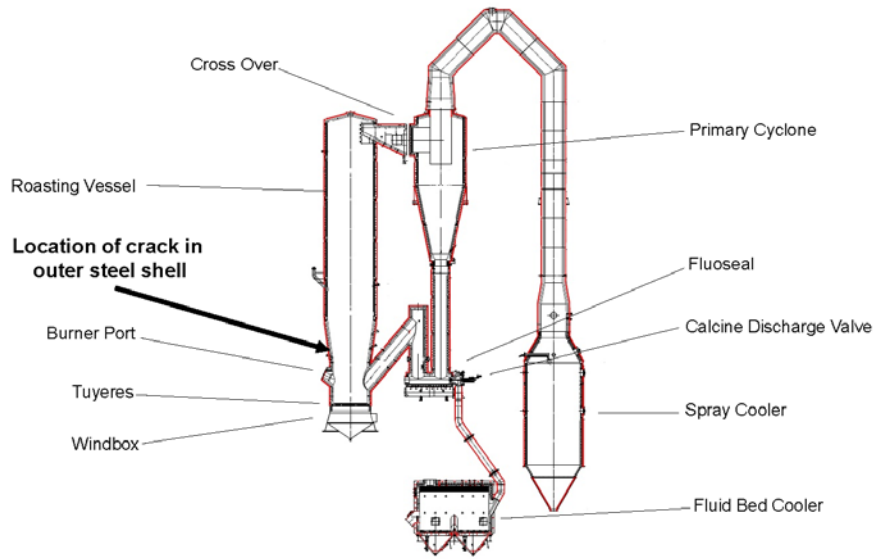

Figure 1: Schematic Diagram of the Syama Sulphide Roaster

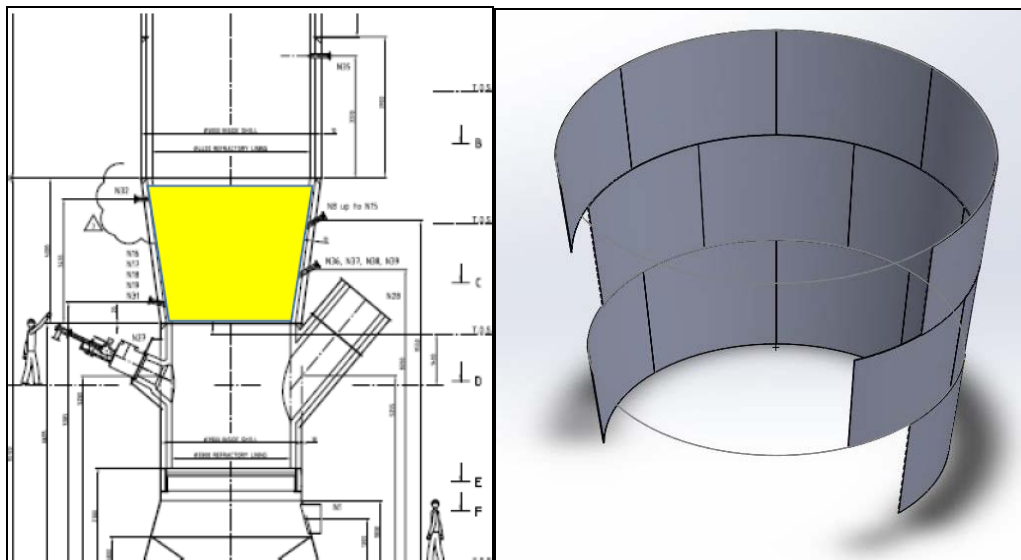

Figure 2: Location of area to be repaired, and depiction of repair method of the Syama Sulphide Roaster



Figure 3: Photo showing progress of repairs to the Roaster. New plates have been welded to form a shell around the damaged area of the Roaster as depicted in Figure 2



Resolute

ASX Announcement

About Resolute

Resolute is a successful, dividend paying gold miner with 30 years of experience as an explorer, developer and operator of gold mines in Australia and Africa which have produced more than eight million ounces of gold.

Resolute's production and cost guidance for the 12 months to 31 December 2019 is 400,000 ounces of gold at an All-In Sustaining Cost of US\$1,020 per ounce.

Resolute owns four gold mines. Its flagship asset is the world class Syama Gold Mine in Mali (Syama) which can produce more than 300,000 ounces of gold per annum from existing processing infrastructure. Resolute is currently commissioning the world's first fully automated underground mine at Syama which will deliver a low cost, large scale operation with a mine life beyond 2032. The Mako Gold Mine in Senegal is a high quality, low cost asset with average annual production of ~140,000 ounces of gold. The Ravenswood Gold Mine in Australia and the Bibiani Gold Mine in Ghana are existing largescale assets which provide Resolute with significant production growth potential. Resolute has a pathway to annual gold production in excess of 500,000 ounces from a Global Mineral Resource base of more than 18 million ounces of gold.

Resolute trades on the Australian Securities Exchange (ASX) and the London Stock Exchange (LSE) under the ticker RSG.

Contact Information

Resolute

John Welborn, Managing Director & CEO
Jeremy Meynert, General Manager – BD & IR
Telephone: +61 8 9261 6100

Email: contact@rml.com.au

Web: www.rml.com.au

Berenberg (UK Corporate Broker)

Matthew Armit / Detlir Elezi
Telephone: +44 20 3207 7800

Tavistock (UK Public Relations)

Jos Simson / Charles Vivian / Emily Fenton / Annabel de Morgan
Telephone: +44 207 920 3150 / +44 778 855 4035

Email: resolute@tavistock.co.uk

Follow Resolute



ASX/LSE: RSG Capital Summary

Fully Paid Ordinary Shares: 903,153,734
Current Share Price (ASX):
A\$1.15 as at 15 November 2019
Market Capitalisation: A\$1.04 billion
FY19 Guidance (to 31 December):
400,000oz at an AISC of US\$1,020/oz

Board of Directors

Mr Martin Botha *Non-Executive Chairman*
Mr John Welborn *Managing Director & CEO*
Ms Yasmin Broughton *Non-Executive Director*
Mr Mark Potts *Non-Executive Director*
Ms Sabina Shugg *Non-Executive Director*
Mr Peter Sullivan *Non-Executive Director*

Contact

John Welborn *Managing Director & CEO*
Jeremy Meynert *GM – BD & IR*
Level 2, Australia Place | 15-17 William St
Perth, Western Australia 6000
T: +61 8 9261 6100 | F: +61 8 9322 7597
E: contact@rml.com.au